



United States
Department of
Agriculture

Soil
Conservation
Service

P.O. Box 2890
Washington, D.C.
20013

March 5, 1986

DESIGN NOTE NO. 6 (Second Edition)
210-VI

SUBJECT: ENG - RIPRAP LINED PLUNGE POOL FOR CANTILEVER OUTLET

Purpose. To distribute Design Note No. 6 (Second Edition), "Riprap Lined Plunge Pool for Cantilever Outlet."

Effective Date. Effective when received.

Explanation. Design Note No. 6 was originally issued in 1969 and was based on research reported in 1967. This second edition was developed based on recently reported research by Fred W. Blaisdell of the Agricultural Research Service. The need for a revision of the original Design Note No. 6 has been identified by several reported situations of riprap being displaced from the plunge pool.

The Blaisdell developed mathematical model is in overall agreement with the experimental data. The purpose of this edition of the design note is to present Blaisdell's final design equations with modifications to facilitate construction and still meet the minimum design requirement.

Filing Instructions. Discard the 1969 edition of Design Note No. 6 and file this second edition with other design notes.

Distribution. The design note should be useful to professionals designing or reviewing the design of an energy dissipator at the downstream end of a conduit spillway. Initial distribution is shown on the reverse side. Additional copies may be obtained from Central Supply.

JOSEPH W. HAAS
Deputy Chief for Technology

Enclosure

DIST: DN-6



)



Design Note No. 6 (Second Edition)*

Subject: Riprap Lined Plunge Pool for Cantilever Outlet

INTRODUCTION

The energy in flow exiting from a spillway usually requires dissipation before being released to the outlet channel. For flow exiting from a conduit, when an open plunge pool is acceptable, an excavated riprap-lined hole at the downstream end of the conduit can be an economical energy dissipator. However, the size of plunge pool, location relative to the conduit outlet, and size of riprap must be properly designed for the plunge pool to operate successfully. Successful operation consists of negligible kinetic energy in the outflow, no erosion or loss of the plunge pool foundation soil due to the turbulence in the process of energy dissipation, and no displacement of the riprap.

Design Note No. 6, originally issued in 1969, was based on research reported in 1967. This second edition was developed based on recently reported research (Blaisdell and Anderson 1984). The need for a revision was identified by several reported situations of riprap being displaced from the plunge pool.

Fred W. Blaisdell, Research Hydraulic Engineer, of the Agricultural Research Service conducted experiments at the Saint Anthony Falls Hydraulic Laboratory of the University of Minnesota in Minneapolis to evaluate the scour at cantilevered pipe spillway outlets. The Blaisdell developed mathematical model indicates an overall agreement with the experimental data. The final equations for the design of plunge pool energy dissipators for cantilevered pipe spillways were presented at the ASCE Hydraulic Division Conference in Coeur d'Alene, Idaho, August, 1984. The purpose of this edition of the design note is to present the final design equations with modifications to facilitate the evaluation of plunge pool shape, length, width, depth, position in relation to the outlet end of the conduit, and plunge pool volumes. Figures 1 and 2 illustrate the plunge pool layout dimensions.

DISCHARGE PARAMETER

The plunge pool dimensions were developed using a discharge parameter. The parameter is based on the design discharge, Q , pipe diameter, D , and combined with the acceleration of gravity, g , resulting in a

*Prepared by H. J. Goon, Design Unit, Engineering Division, Washington, D.C.

dimensionless parameter of $\frac{Q}{\sqrt{gD^5}}$. This is very convenient since Q and D are known prior to the plunge pool design.

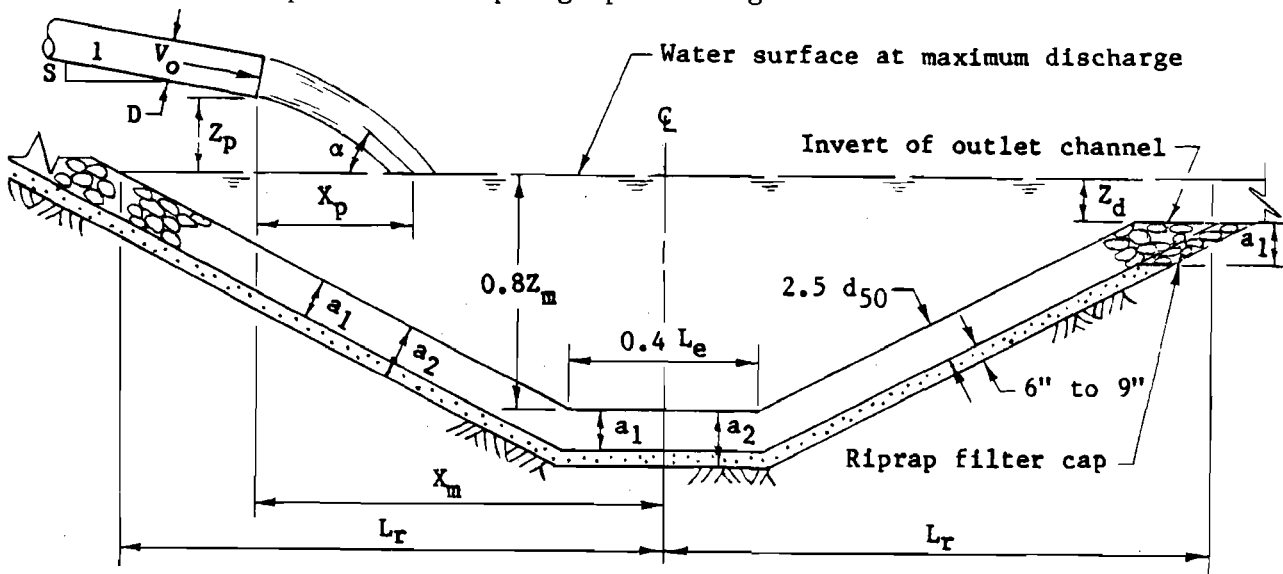

Figure 1 -- Plunge pool definition sketch

DISCHARGE JET TRAJECTORY

The plunge pool location is determined by the discharge jet trajectory. The location of the plunge pool centerline downstream from the discharge end of the pipe is dependent on the jet velocity and angle of impingement with the pool surface as well as the plunge pool depth.

The jet impingement velocity and angle of entry into the pool can be determined from the pipe exit slope, pipe discharge velocity, and height of pipe invert above the water surface. The height of pipe invert above the water surface, Z_p , should be measured from the tailwater elevation for the associated discharge used for the plunge pool design. The discharge should be the maximum prior to any secondary spillway flow. The pipe slope is $\frac{S}{\sqrt{1 - S^2}}$, where S is the sine of the angle whose

tangent is the slope of the pipe. The discharge velocity, V_o , is computed based on the design discharge and the conduit cross-sectional area. The path of the free falling jet is a parabola between the pipe exit and tailwater surface where the jet enters the water with the impingement velocity, V_p , and the slope, $\tan \alpha$. The horizontal distance, X_p , from the pipe exit to where the jet plunges into the tailwater with horizontal velocity, V_h , and vertical velocity, V_v , is given in Eq. 5; where

$$V_h = V_o \cos (\sin^{-1} S) \quad \text{Eq. 1}$$

$$V_v = \sqrt{(V_o S)^2 + 2g \left[Z_p + \frac{D}{2} \cos (\sin^{-1} S) \right]} \quad \text{Eq. 2}$$

$$\tan \alpha = \frac{V_v}{V_h} \quad \text{Eq. 3}$$

$$V_p = \sqrt{V_h^2 + V_v^2} \quad \text{Eq. 4}$$

$$X_p = \frac{V_h}{g} (V_v - V_o S) \quad \text{Eq. 5}$$

PLUNGE POOL DEPTH

The depth of erosion created by the discharging jet can be controlled by the bed material size. The bed material is represented by its mean grain size, d_{50} , the size of which 50 percent by weight is finer in diameter. The research tests were run on noncohesive materials. Therefore, this design procedure is appropriate for soil and rock bed material that perform as single grain material in resisting erosion. The d_{50} size for riprap lining material may be varied to adjust the erosion depth. The plunge pool depth is computed using a densimetric Froude number, F_d , as follows:

$$F_d = \frac{V_p}{\sqrt{gd_{50} (\rho_s - \rho)/\rho}} \quad \text{Eq. 6}$$

where: ρ_s = Bed material or riprap particle density
 ρ = Water density

For $\frac{Z_p}{D} < 1$, the maximum eroded depth is computed by the equation

$$Z_m = 7.5 D \left[1 - e^{-0.6 (F_d - 2)} \right] \quad \text{Eq. 7a}$$

For $\frac{Z_p}{D} > 1$, the maximum eroded depth is computed by the equation

$$Z_m = 10.5 D \left[1 - e^{-0.35 (F_d - 2)} \right] \quad \text{Eq. 7b}$$

The effect of a horizontal ledge or a nonerodible layer on the shape of the plunge pool above the layer was tested and found to be a minimal.

The dimensions of the plunge pool are functions of $\frac{Z_m}{D}$. When the plunge pool dimensions are based on the value of Z_m , the designed contours above the ledge conform to the plunge pool shape. Therefore, it is acceptable to size and construct the plunge pool to 0.8 of the computed maximum depth, Z_m . However, the full value of the computed Z_m , as determined by equation 7a or 7b, must be used in subsequent equations 9, 10, and 11.

The d_{50} bed material size must be checked to assure that it is adequate to control shallow beach type erosion at the top edge of the plunge pool. High flow rates during research testing caused flow to circulate upstream along both sides of the plunge pool. When these circulating flows exceeded the bed material's critical tractive stress, beach erosion at the top edge of the plunge pool occurred. The check for adequate bed material size up to the tailwater elevation is by equation 8. The d_{50} size is adequate and beach erosion will not occur if

$$\frac{Q}{\sqrt{gD^5}} < \left[1.0 + 25 \frac{d_{50}}{D} \right] \quad \text{Eq. 8}$$

If the bed material d_{50} is not large enough, protection will need to be added. In the case of riprap, a larger particle gradation will be required.

LOCATION OF PLUNGE POOL

The horizontal distance, X_m , from the pipe exit to the center of the plunge pool, i.e., where maximum scour depth occurs is

$$X_m = \left[X_p + \frac{Z_m}{\tan \alpha} \right] 1.15 e^{-0.15 \left[Q/(gD^5) \right]^{1/2}} \quad \text{Eq. 9}$$

DIMENSION OF PLUNGE POOL

The plunge pool natural shape is an ellipse with the greater length parallel to the pipe flow. The minimum size based on laboratory tests is the result of flow turbulence, boundary tractive stresses and submerged angle of repose of granular material. The test material d_{50} sizes ranged from 0.5 to 8 mm. The minimum horizontal distance from the center of the plunge pool to the water surface contour at the upstream end of the pool is equal to L_e .

$$L_e = Z_m \left[\frac{3}{2} + \frac{1}{3} \frac{Q}{\sqrt{gD^5}} \right] \quad \text{Eq. 10}$$

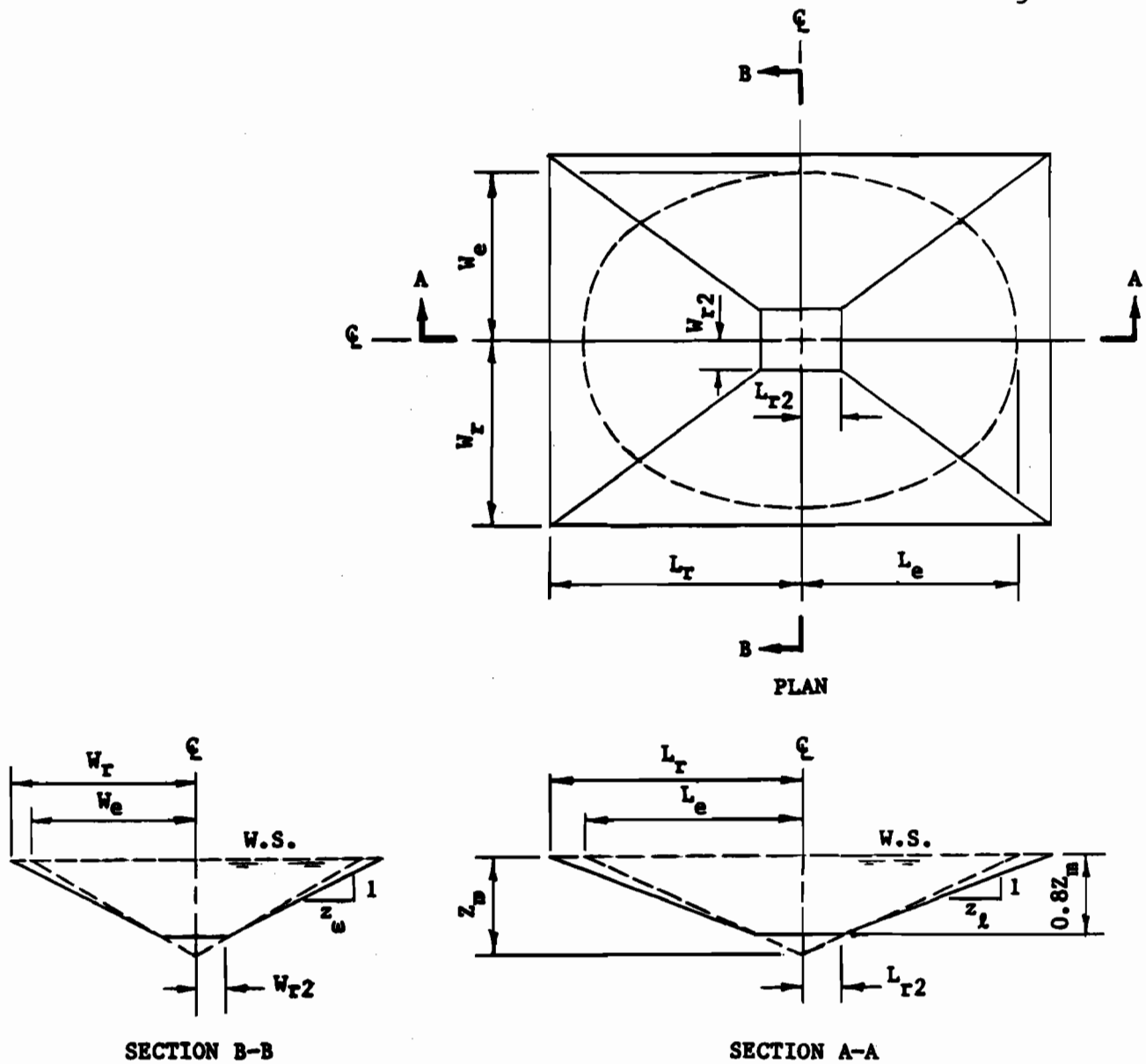

Figure 2 — Plunge Pool

Since the plunge pool shape is that of an ellipse, the distance from the center of the plunge pool to the water surface contour at the projected scour hole slope at the downstream end is also equal to the minimum L_e .

The minimum width of the plunge pool at the center of the pool is equal to $2W_e$.

$$W_e = z_m \left[1.5 + 0.15 \frac{Q}{\sqrt{gD^5}} \right]$$

Eq. 11

Once the minimum width, length, depth and the distance from the end of the pipe to the center of the plunge pool are determined for a given spillway layout and d_{50} particle size, the final design shape and dimensions can be established. It is suggested that a comparable rectangular shape with length equal to $2L_e$ and width equal to $2W_e$ be specified thus facilitating construction and still meeting the minimum design requirement. The dimensions of the rectangular base at the bottom of the plunge pool, $0.8 Z_m$ below the water surface, are length, $2L_{r2}$, and width, $2W_{r2}$ where;

$$2 L_{r2} = 0.4 L_e \quad \text{Eq. 12}$$

$$2 W_{r2} = 0.4 W_e \quad \text{Eq. 13}$$

It is recommended that the excavated side slopes of the plunge pool along the length, z_l and along the width, z_w , be adjusted to acceptable grades for layout and riprap placement purposes, e.g., 3 horizontal to 1 vertical. The final length and width of the plunge pool at the water surface are $2L_r$ and $2W_r$, respectively. Where;

$$L_r = 0.8Z_m z_l + L_{r2} \quad \text{Eq. 14}$$

$$W_r = 0.8Z_m z_w + W_{r2} \quad \text{Eq. 15}$$

If L_r is less than X_m , the water surface contour at the upstream end of the pool is downstream from the end of the conduit. Therefore, L_r should be increased to equal to or greater than X_m .

PLUNGE POOL VOLUMES

The volume, V , in cu. yds. of the plunge pool and lining materials, such as riprap and granular filter, can be determined as frustums of pyramids. For convenience, the appropriate equation is listed below

$$V = \frac{1}{81} [A_1 + A_2 + \sqrt{A_1 A_2}] Z$$

where A_1 is the plan rectangular area of the plunge pool at the invert elevation of the outlet channel, ft^2
 A_2 is the plan rectangular area at the bottom of the plunge pool at a distance Z below the invert elevation of the outlet channel, ft^2

Z is either equal to $0.8Z_m - Z_d$, $0.8Z_m - Z_d + a_1$, or $0.8Z_m - Z_d + a_2$ below the invert elevation of the outlet channel, ft.

a_1 is the thickness of the riprap lining, ft.

a_2 is the thickness of the riprap lining and granular filter material, ft.

Z_d is the water depth above the invert elevation of the outlet channel, ft.

The volumes of riprap and filter material above the invert elevation of the outlet channel depend on the site topography.

PROCEDURE

The step procedure given below is in a form that can easily be programmed on either programmable calculators or microcomputers.

1. Compute $\frac{Q}{\sqrt{gD^5}}$
2. Compute $V_o = \frac{4Q}{\pi D^2}$
3. Compute $V_h = V_o \cos(\sin^{-1} S)$ Eq. 1
- $V_v = \sqrt{(V_o S)^2 + 2g \left[Z_p + \frac{D}{2} \cos(\sin^{-1} S) \right]}$ Eq. 2
- $\tan \alpha = \frac{V_v}{V_h}$ Eq. 3
- $V_p = \sqrt{V_h^2 + V_v^2}$ Eq. 4
- $X_p = \frac{V_h}{g} (V_v - V_o S)$ Eq. 5
4. Compute $F_d = \frac{V_p}{\sqrt{gd_{50}(\rho_s - \rho) / \rho}}$ Eq. 6
5. Compute $\frac{Z_p}{D}$; if < 1 , Go to step 6a ; if > 1 , Go to step 6b
- 6a. Compute $Z_m = 7.5 D [1 - e^{-0.6 (F_d - 2)}]$; Go to step 7 Eq. 7a

6b. Compute $Z_m = 10.5 D [1 - e^{-0.35 (F_d - 2)}]$ Eq. 7b

7. Compute $1.0 + 25 \frac{d_{50}}{D}$ Eq. 8

8. If $\frac{Q}{\sqrt{gD^5}} < 1.0 + 25 \frac{d_{50}}{D}$, then go to step 9; otherwise, make design adjustments to increase d_{50} and return to step 4.

9. Compute $X_m = [X_p + \frac{Z_m}{\tan \alpha}] 1.15 e^{-0.15 [Q/(gD^5)]^{1/2}}$ Eq. 9

10. Compute $L_e = Z_m [\frac{3}{2} + \frac{1}{3} \frac{Q}{\sqrt{gD^5}}]$ Eq. 10

$$W_e = Z_m [1.5 + 0.15 \frac{Q}{\sqrt{gD^5}}] \quad \text{Eq. 11}$$

11. Determine A_2 , plan rectangular area of the plunge pool bottom at $0.8Z_m$ below the water surface

$$L_{r2} = 0.2 L_e$$

$$W_{r2} = 0.2 W_e$$

$$A_2 = 4 L_{r2} W_{r2}$$

12. Check the side slopes of the plunge pool and adjust, if necessary to acceptable grades, z_ℓ and z_ω . The final length and width of the plunge pool at the water surface are $2L_r$ and $2W_r$, respectively.

$$L_r = 0.8 Z_m z_\ell + L_{r2}$$

$$W_r = 0.8 Z_m z_\omega + W_{r2}$$

13. If $L_r < X_m$, increase side slope, z_ℓ , so that $L_r > X_m$

14. Determine A_1 , plan rectangular area of the plunge pool at the invert elevation of the outlet channel

$$A_1 = 4 (L_r - z_\ell Z_d) (W_r - z_\omega Z_d)$$

15. Plunge Pool Volume:

The Volume between a horizontal plane at the invert elevation of the outlet channel and the exposed riprap surface is V_{a0} .

$$V_{a0} = \frac{1}{81} [A_1 + A_2 + \sqrt{A_1 A_2}] [0.8Z_m - Z_d], \text{ cu. yds.}$$

The volume between a horizontal plane at the invert elevation of the outlet channel and a surface at a thickness, a_1 , below the exposed riprap surface is V_{a1} .

$$V_{a1} = \frac{1}{81} [A_{1a1} + A_{2a1} + \sqrt{A_{1a1} A_{2a1}}] [0.8Z_m - Z_d + a_1], \text{ cu. yds.}$$

$$\text{where } A_{1a1} = 4 [L_r - z_\ell Z_d + a_1 \sqrt{1 + z_\ell^2}] [W_r - z_\omega Z_d + a_1 \sqrt{1 + z_\omega^2}]$$

and

$$A_{2a1} = 4 [L_{r2} + a_1 (\sqrt{1 + z_\ell^2} - z_\ell)] [W_{r2} + a_1 (\sqrt{1 + z_\omega^2} - z_\omega)]$$

The volume of riprap at thickness, a_1 , below a horizontal plane at the invert elevation of the outlet channel, exclusive of the volume of the riprap filter cap is $V_{a1} - V_{a0}$, cu. yds.

The volume between a horizontal plane at the invert elevation of the outlet channel and a surface at a thickness, a_2 , below the exposed riprap surface is V_{a2}

$$V_{a2} = \frac{1}{81} [A_{1a2} + A_{2a2} + \sqrt{A_{1a2} A_{2a2}}] [0.8Z_m - Z_d + a_2], \text{ cu. yds.}$$

$$\text{where } A_{1a2} = 4 [L_r - z_\ell Z_d + a_2 \sqrt{1 + z_\ell^2}] [W_r - z_\omega Z_d + a_2 \sqrt{1 + z_\omega^2}]$$

and

$$A_{2a2} = 4 [L_{r2} + a_2 (\sqrt{1 + z_\ell^2} - z_\ell)] [W_{r2} + a_2 (\sqrt{1 + z_\omega^2} - z_\omega)]$$

The volume of filter material of thickness, $a_2 - a_1$, below a horizontal plane at the invert elevation of the outlet channel, including the volume of the riprap filter cap, is equal to $V_{a2} - V_{a1}$, cu. yds.

EXAMPLE

Given:

Invert elevation at outlet end of conduit = 102.5
 Invert elevation of outlet channel = 100.0
 Elevation of tailwater for maximum conduit discharge = 101.5
 $Q = 147$ cfs, $D = 2.5$ ft., $S = 0$
 Riprap size, $d_{50} = 1.0$ ft., $\rho_s = 2.64$
 Thickness of filter material bed = 0.75 ft.

Determine:

- I. Plunge pool position with respect to outlet end of conduit
- II. Plunge pool depth, length, and width
- III. Plunge pool volumes below the invert elevation of outlet channel

Solution:

$$1. \quad \frac{Q}{\sqrt{gD^5}} = \frac{147}{\sqrt{32.16(2.5)^5}} = 2.62$$

$$2. \quad v_o = \frac{4Q}{\pi D^2} = \frac{4(147)}{3.14(2.5)^2} = 30 \text{ ft/sec}$$

$$3. \quad v_h = v_o \cos(\sin^{-1} S) = 30 \text{ ft/sec}$$

$$v_v = \left[(v_o S)^2 + 2g(z_p + \frac{D}{2} \cos(\sin^{-1} S)) \right]^{1/2} = \left[0 + 64.32 \left(1.0 + \frac{2.5}{2} \right) \right]^{1/2}$$

$$= 12.0 \text{ ft/sec}$$

$$\tan \alpha = \frac{v_v}{v_h} = \frac{12.0}{30} = 0.40$$

$$v_p = \sqrt{v_h^2 + v_v^2} = \sqrt{(30)^2 + (12.0)^2} = 32.3 \text{ ft/sec}$$

$$x_p = \frac{v_h}{g} (v_v - v_o S) = \frac{30}{32.16} (12.0) = 11.2 \text{ ft}$$

$$4. \quad F_d = \frac{v_p}{\sqrt{gd_{50} (\rho_s - \rho) / \rho}} = \frac{32.3}{\sqrt{32.16(1) (2.64 - 1) / 1}} = 4.45$$

$$5. \quad \frac{z_p}{D} = \frac{1}{2.5} = 0.4 < 1, \text{ therefore use Equation 6a}$$

$$6. \quad z_m = 7.5D [1 - e^{-0.6 (F_d - 2)}] = 7.5 (2.5) [1 - e^{-1.47}] = 14.4 \text{ ft}$$

$$7. \quad 1.0 + 25 \frac{d_{50}}{D} = 1.0 + 25 \frac{1}{2.5} = 11$$

$$8. \quad \frac{Q}{\sqrt{gD^5}} < [1.0 + 25 \frac{d_{50}}{D}]; \text{ therefore riprap size is adequate to prevent significant shallow erosion enlargement at water surface elevation.}$$

9. Plunge pool position from outlet end of pipe to center of pool, X_m

$$X_m = [X_p + \frac{Z_m}{\tan \alpha}] 1.15 e^{-0.15 (Q/\sqrt{gD^5})}$$

$$X_m = [11.2 + \frac{14.4}{0.40}] 1.15 e^{-0.15(2.62)} = 36.6 \text{ ft}$$

10. Plunge Pool Dimensions

$$\text{depth at center} = 0.8 Z_m = 0.8 (14.4) = 11.5 \text{ ft}$$

$$L_e = Z_m \left[\frac{3}{2} + \frac{1}{3} \frac{Q}{\sqrt{gD^5}} \right] = 14.4 \left[\frac{3}{2} + \frac{2.62}{3} \right] = 34.2 \text{ ft}$$

$$W_e = Z_m \left[1.5 + 0.15 \frac{Q}{\sqrt{gD^5}} \right] = 14.4 [1.5 + 0.15 (2.62)] = 27.3 \text{ ft}$$

$$11. \quad L_{r2} = 0.2 L_e = 0.2(34.2) = 6.8 \text{ ft.}$$

$$W_{r2} = 0.2 W_e = 0.2(27.3) = 5.5 \text{ ft.}$$

$$A_2 = 4 L_{r2} W_{r2} = 4(6.8)(5.5) = 150 \text{ ft}^2$$

$$12. \quad z_\ell = \frac{L_e - L_{r2}}{0.8Z_m} = \frac{34.2 - 6.8}{11.5} = 2.4; \text{ Adjust } z_\ell \text{ to } 3.0$$

$$\therefore L_r = 0.8Z_m z_\ell + L_{r2} = 11.5 (3.0) + 6.8 = 41.3 \text{ ft.}$$

$$z_\omega = \frac{W_e - W_{r2}}{0.8Z_m} = \frac{27.3 - 5.5}{11.5} = 1.9; \text{ Adjust } z_\omega \text{ to } 2.0$$

$$\therefore W_r = 0.8Z_m z_\omega + W_{r2} = 11.5 (2.0) + 5.5 = 28.5 \text{ ft.}$$

$$13. \quad L_r = 41.3 > X_m = 36.6 \quad \text{O.K.}$$

$$14. \quad A_1 = 4 (L_r - z_\ell Z_d) (W_r - z_\omega Z_d) = 4 [41.3 - 3(1.5)] [28.5 - 2(1.5)] \\ = 3754 \text{ ft}^2$$

$$15. \quad V_{ao} = \frac{1}{81} [A_1 + A_2 + \sqrt{A_1 A_2}] [0.8Z_m - Z_d] \\ = \frac{1}{81} [3754 + 150 + \sqrt{3754 \times 150}] [11.5 - 1.5] = 574 \text{ cu. yds.}$$

$$\begin{aligned}
 A_{1a1} &= 4 [L_r - z_l z_d + a_1 \sqrt{1 + z_l^2}] [W_r - z_w z_d + a_1 \sqrt{1 + z_w^2}] \\
 &= 4 [41.3 - 3(1.5) + 2.5 \sqrt{1 + 3^2}] [28.5 - 2(1.5) + 2.5 \sqrt{1 + 2^2}] \\
 &= 5560 \text{ ft}^2
 \end{aligned}$$

$$\begin{aligned}
 A_{2a1} &= 4 [L_{r2} + a_1 (\sqrt{1 + z_l^2} - z_l)] [W_{r2} + a_1 (\sqrt{1 + \frac{z_w^2}{2}} - z_w)] \\
 &= 4 [6.8 + 2.5 (\sqrt{1 + 3^2} - 3)] [5.5 + 2.5 (\sqrt{1 + 2^2} - 2)] = 176 \text{ ft}^2
 \end{aligned}$$

$$\begin{aligned}
 V_{a1} &= \frac{1}{81} [A_{1a1} + A_{2a1} + \sqrt{A_{1a1} A_{2a1}}] [0.8z_m - z_d + a_1] \\
 &= \frac{1}{81} [5560 + 176 + \sqrt{5560 \times 176}] [11.5 - 1.5 + 2.5] = 1038 \text{ cu. yds.}
 \end{aligned}$$

$$\text{Volume of riprap} = V_{a1} - V_{a0} = 1038 - 574 = 464 \text{ cu. yds.}$$

$$A_{1a2} = 4 [41.3 - 4.5 + 3.25 \sqrt{10}] [28.5 - 3 + 3.25 \sqrt{5}] = 6170 \text{ ft}^2$$

$$A_{2a2} = 4 [6.8 + 3.25 (\sqrt{10} - 3)] [5.5 + 3.25 (\sqrt{5} - 2)] = 184 \text{ ft}^2$$

$$V_{a2} = \frac{1}{81} [6170 + 184 + \sqrt{6170 \times 184}] [11.5 - 1.5 + 3.25] = 1214 \text{ cu. yds.}$$

$$\text{Volume of filter} = V_{a2} - V_{a1} = 1214 - 1038 = 176 \text{ cu. yds.}$$

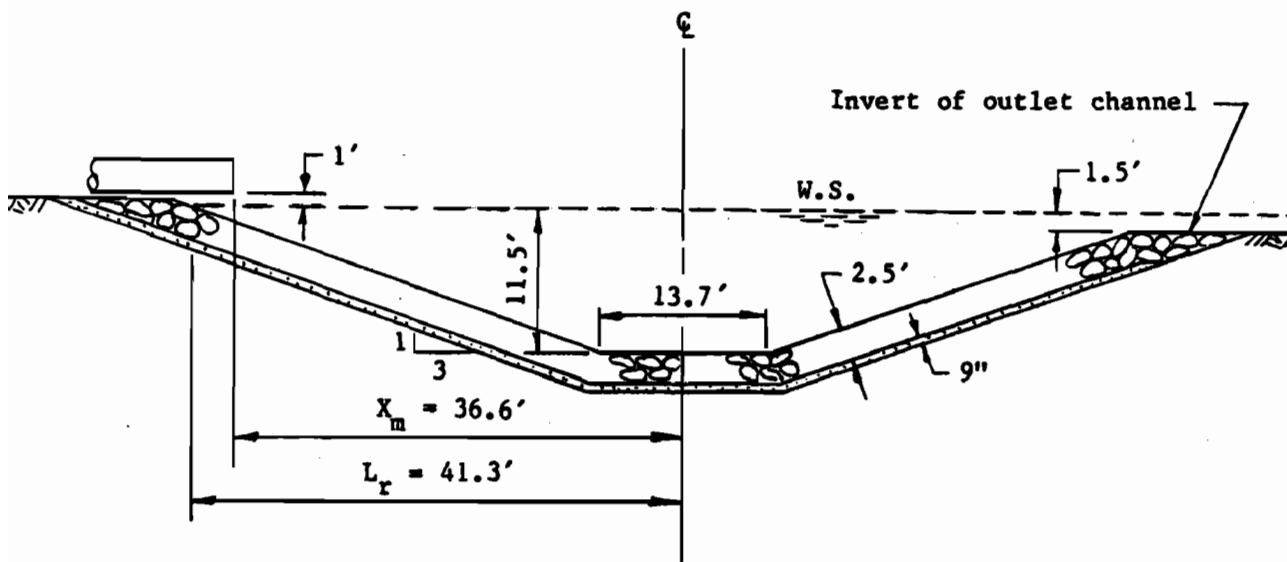

NOMENCLATURE

a_1	≡	Thickness of riprap, ft
a_2	≡	Thickness of riprap and filter material, ft
A_1	≡	Plan rectangular area of the plunge pool at the invert elevation of the outlet channel, ft ²
A_2	≡	Plan rectangular area at the bottom of the plunge pool at a distance Z below the invert elevation of the outlet channel, ft ² .
d_{50}	≡	Size of rock in riprap of which 50 percent by weight is finer, ft
D	≡	Cantilever outlet pipe diameter, ft
e	≡	Base of natural logarithms
F_d	≡	Densimetric Froude number
g	≡	Acceleration of gravity, ft/sec ²
L_e	≡	Minimum horizontal distance from the center of the pool to the water surface contour at the upstream or downstream end of an elliptical-shape plunge pool, ft
L_r	≡	Adjusted horizontal distance from the center of the pool to the water surface contour at the upstream or downstream end of the rectangular-shape plunge pool, ft
L_{r2}	≡	One-half the length of the bottom of a rectangular-shape plunge pool, ft
Q	≡	Design discharge, cfs
S	≡	Sine of the angle whose tangent is the slope of the pipe
V_{a0}	≡	Volume of the plunge pool between the invert elevation of the outlet channel and the exposed riprap surface, cu. yds.
V_{a1}	≡	Volume of the plunge pool between the invert elevation of the outlet channel and a surface at a thickness, a_1 , below the exposed riprap surface, cu. yds.
V_{a2}	≡	Volume of the plunge pool between the invert elevation of the outlet channel and a surface at a thickness, a_2 , below the exposed riprap surface, cu. yds.

V_h	≡	Horizontal component of the jet impingement velocity, V_p , ft/sec
V_o	≡	Velocity in the pipe corresponding to the design discharge, Q , ft/sec
V_p	≡	Velocity where the jet plunges into the water surface, ft/sec
V_v	≡	Vertical component of the jet impingement velocity, V_p , ft/sec
W_e	≡	One-half the minimum width at the center of the elliptical- shape plunge pool at the water surface elevation, ft
W_r	≡	One-half the adjusted width at the center of the rectangular- shape plunge pool at the water surface elevation, ft
W_{r2}	≡	One-half the width of the bottom of a rectangular plunge pool, ft
X_m	≡	Horizontal distance from the pipe exit to the center of the plunge pool, ft
X_p	≡	Horizontal distance from the pipe exit to the center of the jet plunging into the water surface, ft
z_l	≡	Side slope ratio of the upstream or downstream slope of the rectangular-shape plunge pool
Z_w	≡	Side slope ratio of the side slopes of the rectangular- shape plunge pool
Z_d	≡	Water depth above the invert elevation of the outlet channel, ft
Z_m	≡	Maximum computed depth of the plunge pool, ft
Z_p	≡	Vertical distance from the tailwater surface to the cantilever pipe invert, ft
ρ	≡	Water density
ρ_s	≡	Bed material or riprap particle density
α	≡	Jet impingement angle where the jet plunges into the water surface

REFERENCES

Blaisdell, F. W., and Anderson, C. L. 1984. Pipe spillway plunge pool design equations. Proceedings of the conference - water for resource development, Hydraulics Division, ASCE, Coeur d'Alene, Idaho.

Anderson, C. L. and Blaisdell, F. W. 1982. Plunge pool energy dissipator for pipe spillways, Proceedings of the conference - applying research to hydraulic practice, ASCE, Jackson, Mississippi, p. 289-297.

Blaisdell, F. W., Anderson, C. L., and Hebaus, G. G. 1981. Ultimate dimensions of local scour. Journal of the Hydraulics Division, ASCE, Vol. 107, No. HY3, Proc. Paper 16144, p. 327-337.

(210-VI-DN-6, Second Ed., January 1986)





